

PROJECT NAME: \_\_\_\_\_ CAT. #: \_\_\_\_\_  
 NOTES: \_\_\_\_\_ FIXTURE SCHEDULE: \_\_\_\_\_

# Dusk to Dawn Barn Light



### Description:

The Dusk to Dawn Barn Light is the perfect solution for many general purpose outdoor applications. It replaces traditional 100W-175W HID fixtures and can mount directly on a wall or to a pole. The prismatic lens offers a uniform distribution pattern as well as IP65 protection against the elements. All fixtures include a curved arm and photocell for dusk to dawn operation. The fixture also allows the ability to select from three different CCT's and change to a different c-Max control which can add motion sensing, grouping and scheduling capabilities. The 60W is wattage selectable and both versions have a high voltage (277-480V) factory installed option available. The Maxlite Barn Light offers the perfect economical area and security lighting solution.

### Features:

- 120-277V 50/60Hz, High Voltage 277-480V factory installed option available
- 60W is wattage selectable (36/48/60W)
- CCT Selectable between 3/4/5K

### Installation:

- Direct Wall Mount
- Pole Mount
- 24" curved arm included (18" projection)
- Neck accommodates 1 5/8" and 2 3/8" (retrofits) OD brackets

### Construction:

- Die Cast Aluminum housing with corrosion resistant powder coat finish (grey)
- Impact resistant, UV stabilized polycarbonate prismatic lens
- 24" curved aluminum arm with hardware

### Listings:

- UL listed for Wet Locations, Outdoor, IP65
- TAA Compliant standard
- DLC Premium

### Controls:

- Includes c-Max photocell
- Controls receptacle allows photocell to be replaced by different field installable c-Max controls (see Accessories chart)
- Third party control systems also available



**CCT Select Switch**



**Wattage Select Switch**

## Ordering Information

FAMILY	WATTAGE	VOLTAGE	DISTRIBUTION	-	CCT	FINISH	OPTIONS
DBL= Dusk to Dawn Barn Light	40= 40W	U= 120-277V	T5= Type V		CS= CCT Selectable (3/4/5K)***	G= Grey <i>Contact Maxlite for additional finishes</i>	PN= c-Max Photocell included  <i>Additional field installable c-Max controls available, see Accessory chart below.</i>
	60= Wattage Selectable (36W,48W,60W)*	U= 120-277V H= 277-480V**			WCS= CCT/Watt Selectable (3/4/5K and 36/48/60W)***		

\*Default wattage for the 60W wattage selectable is 60W  
 \*\*Bi-level dimming and TAA Compliance not available in HV 277-480V models  
 \*\*\*Based on CCT Selected and color mixing, all LEDs may not be activated

## Dusk to Dawn Barn Light

### Stocked Items

MODEL NUMBER	ORDER CODE	DLC ID #
104048	DBL40UT5-CSGPN	S-KTMH3U
108567	DBL60UT5-WCSGPN	S-KR3QSE





### Specifications

	DBL40UT5-CSGPN			DBL60UT5-WCSGPN**		
	3000K	4000K	5000K	3000K	4000K	5000K
Nominal Wattage (W)	40			60		
Lumens (lm)	4,880	5,220	5,300	7,130	7,750	7,850
Efficacy (lm/W)	128	137	139	123	133	135
Beam Type	Type 5					
Electrical	120-277V 50/60Hz (4KV surge protection), 277-480V option available (6KV surge protection)					
CRI	≥80					
CCT (K)	CCT Selectable - 3000K, 4000K, 5000K*					
Dimming	0-10V, 10-100%					
L70 Lifetime (hrs)	≥ 165,000					
Power Factor	≥ 0.9					
Operating Temperature	-40°F to 122°F (-40°C to 50°C)					
Listings	cULus, DLC Premium, FCC, ANSI 1.5G					
Environment	UL Wet Location, IP65					
Warranty	5 Year warranty. Check <a href="http://maxlite.com/warranties">maxlite.com/warranties</a> for details.					

\*CCT default is 5000K

\*\* Wattage Selectable Lumens - 36W = 4,730-5,210, 48W = 5,990-6,600

### Accessories

ORDER CODE	MODEL NUMBER	DESCRIPTION	IMAGE
105568	CN-RTPCT	Control Node Rectangular, Photocell, Translucent (included in standard fixture, no remote control programming required)	
105564	CN-RTMST	Control Node Rectangular, Microwave Motion Sensor/Photocell, Translucent (field installable, requires at least one CN-REMOTE per project to program)	
105892	NN-RTW	Network Node Rectangular, White (field installable, requires c-Max app to program scheduling and grouping)	
105567	CN-REMOTE	Control Node Remote Control (at least one per project required to program CN-RTMST)	

## Dusk to Dawn Barn Light

### Dimensions

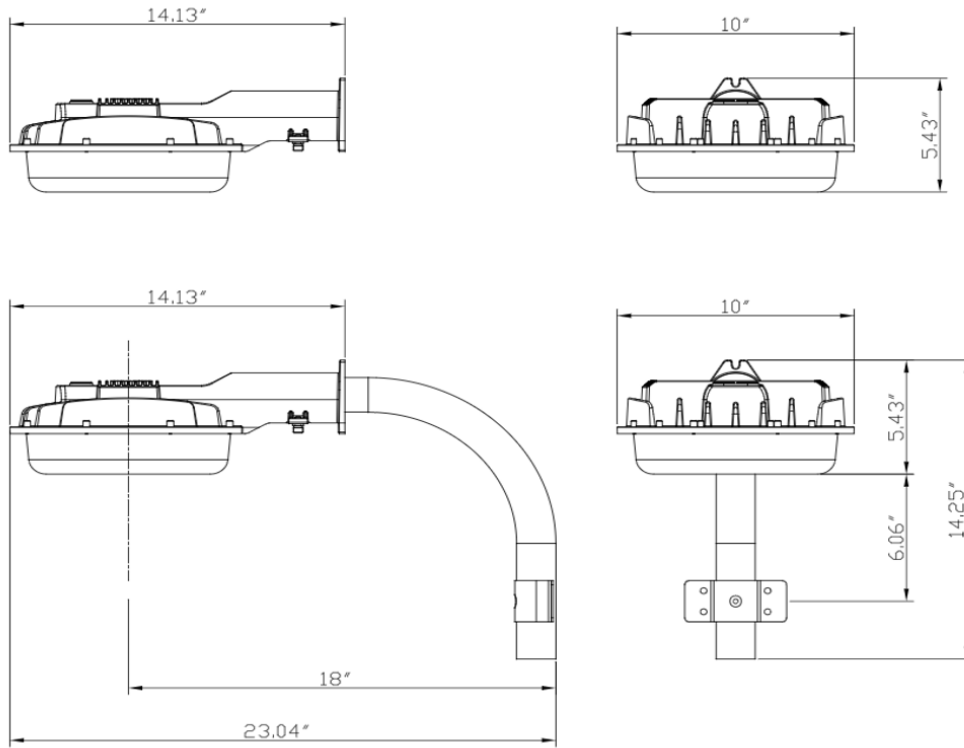

### Iso Footcandle:

Each gridline represents one mounting height.  
For mounting heights other than noted multiply FC by the below factor.

$$\frac{(\text{Chart's Mtg Height})^2}{(\text{Actual Mtg Height})^2}$$

#### LEGEND

- 0.2 fc
- 0.5 fc
- 1 fc
- 2 fc

### 40W - 20' MOUNTING HEIGHT:

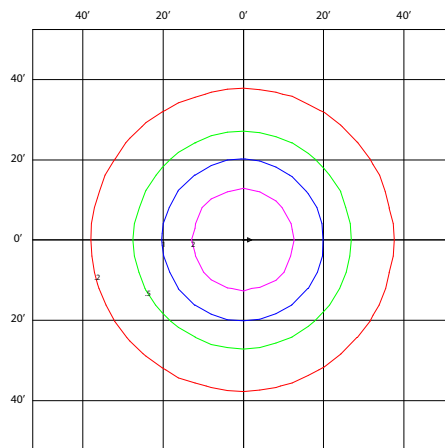

### 60W - 25' MOUNTING HEIGHT:

