

PUFF FLUSH MOUNT
CCT SELECTABLE SERIES



Small

Medium

Large

Highly customizable, this Title 24 offering fits commercial, multi-unit residential and hospitality spaces with CCT Selectability, options such as Bilevel motion sensor or Battery Backup, voltages ranging from 120 to 120-277V with Triac as well as 0-10V dimming. Keep the same look throughout your building!



FEATURES:

- 2700K/3000K/3500K/4000K/5000K CCT Selectable
- 120-277V available
- Bi-level motion sensor and Battery back up options

DIMMING:

- 120V option available with 120V triac dimming (10%)
- 120-277V option available with 0-10V dimming (10%)

MOUNTING:

- Ceiling flush mount

CONSTRUCTION:

- Steel housing
- Polystyrene plastic lens

CONTROLS:

- 120-277V models are available with a bi-level motion sensor

LISTINGS:

- ETL listed for damp locations, Indoor
- Supports T24 Part 6 high efficacy lighting requirements
- JA8 Listed

WARRANTY:

5-year standard warranty* (further details available at www.maxlite.com/warranties)

*Product may be eligible for a warranty extension to 10 years, for an additional fee. Contact MaxLite for details.

ORDERING STRUCTURE

FAMILY	TYPE	SIZE	STYLE	FINISH	VOLTAGE	WATTAGE (NOMINAL)	CRI	CCT	OPTIONS
ML2= Ceiling Flush Mounts	LA= LED integrated	S= Small	P= Puff	WH= White	[BLANK]= 120V, Triac dimming U= 120-277V, 0-10V dimming	16= 16W	9= 90 CRI	CS= 2700K/3000K/3500K/4000K/5000K CCT Selectable	BLANK= None
		M= Medium				20= 20W			MSV ^{1,2,4} = Bi-Level motion sensor
		L= Large				24= 24W			

¹MSV and EM options are only available with the 120-277V version

²When using MS or EM, resulting input wattage is 1W higher

³The nominal lumen output is 250 lm for 90 minutes in emergency mode

⁴MSV and EM is not available for Small models

ACCESSORY (SOLD SEPARATELY)

ORDER CODE	MODEL NUMBER	DESCRIPTION	IMAGE
105035	RMMH-10	Remote Control (For Motion Sensor)	
104799	RMRC-100	Remote Control (Line Voltage Microwave Bi-Level Sensor)	
106318	NPP-300W	Network Power Pack	
107788	NPPSL-PSW	Network Power Pack PIR Sensor	

ORDER CODE

ORDER CODE	MODEL NUMBER	ES ID
103950	ML2LASPWH169CS	2362780
104651	ML2LAMPWH209CS	2363296
104652	ML2LALPWH249CS	2363297
104653	ML2LASPWHU169CS	2362863
104654	ML2LAMPWHU209CS	2362867
104655	ML2LALPWHU249CS	2362871

COMPATIBLE DIMMERS

DIMMER BRAND	MODELS	FIXTURE MODEL
LUTRON	DVCL-153P, CTCL-153P, TGCL-153P, PD-6WCL, MACL-153M	120V
	IPL06-10, 6672-1L, 6674-P0	120-277V
LEVITON	NTSTV, DVSTV, MS-Z101	120V
	IP70-LFZ, SR1200ZTUNV	120-277V

SPECIFICATIONS

SPECIFICATIONS	ML2LASPWH169CS	ML2LAMPWH209CS	ML2LALPWH249CS	ML2LASPWHU169CS	ML2LAMPWHU209CS	ML2LALPWHU249CS
	DETAILS					
Nominal Wattage (W)	16W	20W	25W	16W	20W	24W
Lumens Delivered (lm) @ 2700K	1100	1400	1700	1300	1500	2000
EM Nominal Lumen Delivered (lm)	250 lm for 90 mins					
Equivalency	75W INC	100W INC	125W INC	100W INC	125W INC	150W INC
Efficacy (lm/W)	69	70	68	81	80	83
Beam Angle	120°					
CRI	≥90					
Color Temperature (K)	2700K, 3000K, 3500K, 4000K, 5000K					
L70 Lifetime (Hrs)	≥54,000 Hrs					
Voltage	120V (Triac Dimming, 10%) & 120-277V (0-10V Dimming, 10%)					
Power Factor	≥0.90					
Housing	Steel					
Lens	Polystyrene plastic					
Mounting	Ceiling flush mount					
Operating Temperature	-4°F to 104°F					
Listings	Title 24, cETLus, FCC					
Environment	Damp locations, Indoor					
Warranty	5 Years					

PRODUCT DIMENSIONS:

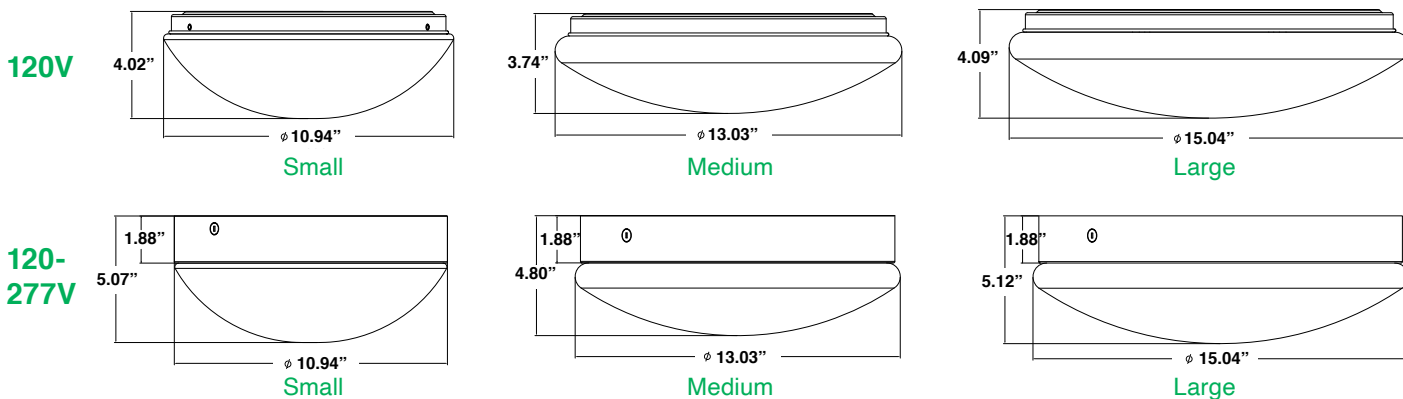

MOTION SENSOR DIP SETTING:

REMOTE CONTROL AVAILABLE:

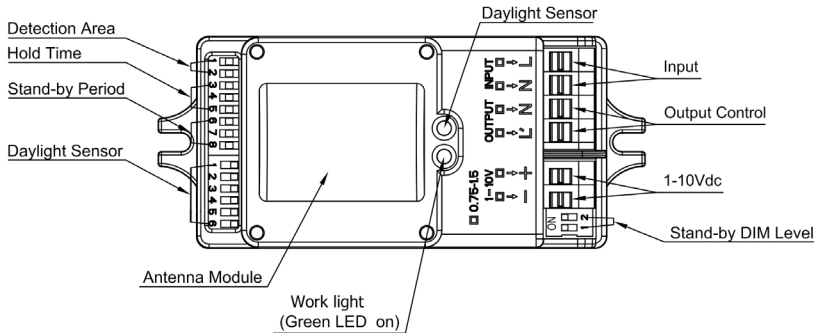

RMMH-10
(SOLD SEPARATELY)

1) DETECTION AREA

	1	2	
I	ON	ON	100%
II	ON	-	75%
III	-	ON	50%
IV	-	-	10%

2) HOLD TIME

	3	4	5	
I	ON	ON	ON	5s
II	-	ON	ON	30s
III	ON	-	ON	90s
IV	-	-	ON	3min
V	ON	ON	-	20min
VI	-	-	-	30min

3) STAND-BY PERIOD

	6	7	8	
I	ON	ON	ON	0s
II	-	ON	ON	5s
III	ON	-	ON	5min
IV	-	-	ON	10min
V	ON	ON	-	30min
VI	-	ON	-	60min
VII	-	-	-	+∞

4) DAYLIGHT SENSOR

	1	2	3	4	5	6	
I	ON	ON	ON	ON	ON	ON	2lux
II	-	ON	ON	ON	ON	ON	5lux
III	ON	-	ON	ON	ON	ON	15lux
IV	ON	ON	-	ON	ON	ON	25lux
V	ON	ON	ON	-	ON	ON	50lux
VI	ON	ON	ON	ON	-	ON	100lux
VII	ON	ON	ON	ON	ON	-	Disable*

5) STAND-BY DIM LEVEL

	1	2	
I	ON	ON	50%
II	ON	-	35%
III	-	-	25%

MOTION SENSOR RADIATION PATTERN:

NORMAL SPEED

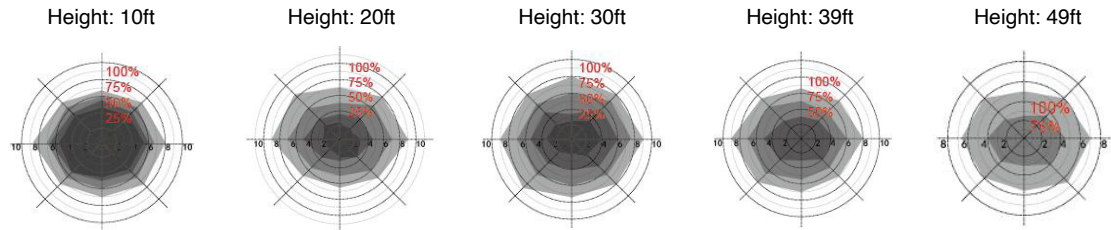

SLOW SPEED

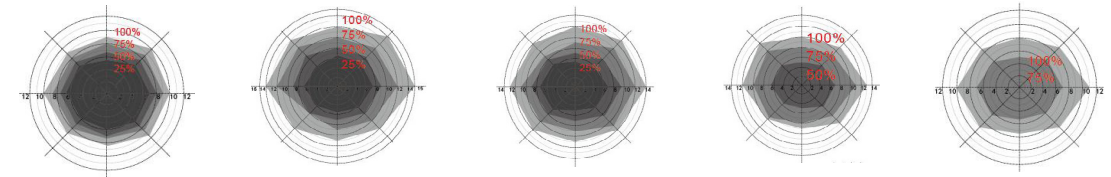

- 1- 100%, 75%, 50% or 25% represent the detection sensitivity
- 2- Normal speed is 1m/s or 2.23 mph
- 3- Slow speed is 0.3 m/s or 0.67 mph
- 4- There is only a 100%, 75% or 50% detection sensitivity at 32 ft height or more (no detection at 25%)

LINE VOLTAGE MICROWAVE BI-LEVEL SENSOR:



Features:

- Tri-level controls including on/off and Bi-level dimming
- 0-10V dimming
- Hold time 10 seconds -15 minutes
- Ambient daylight threshold sensing
- Remote control (optional) to commission
- Easy user reset able functions via DIP switches

REMOTE CONTROL AVAILABLE:



RMRC-100
(SOLD SEPARATELY)

Sensor Coverage:

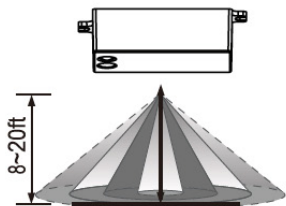

Height of installation 8~20ft

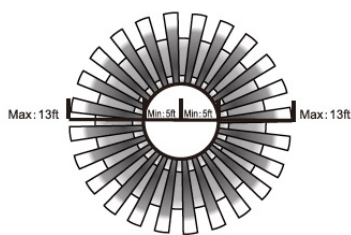

(Height of installation 13ft)
Detection range

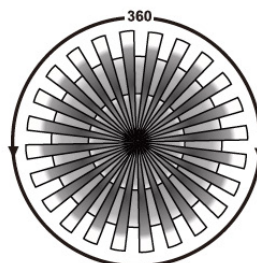

Detection angel

DIP SWITCH INSTRUCTIONS

DETECTION RANGE SETTING (SENSITIVITY)

Detection range can be reduced by selecting the combination on the DIP switches to fit precisely each application :



HOLD TIME SETTING

The lamp can be set to stay ON for any period of time between approximately 10 seconds and a maximum of 15 min. Any movement detected before this time elapse will re-start the timer. It is recommended to select the shortest time for adjusting the detection zone and for performing the walk test. Switch location and hold time of the corresponding table is as follows:



LIGHT-CONTROL SETTING

The chosen lamp response threshold can be infinitely from approx. 10- 50 Lux, switch location and light-control of the corresponding table is as follows :



STAND-BY LIGHT LEVEL SETTING

The corresponding file of switch location and Stand-by Level as follows:



STAND-BY TIME SETTING

File of switch location and stand-by time setting as follows:

