

MaxLite® Square Steel Poles Installation Instructions



General Guideline

The information supplied in this document is a generalized description of the installation of the structures supplied. It is not a comprehensive guide on how to install these structures. Installation contractors must be relied upon for equipment and practices that meet the conditions of each job location.

Maxlite shall not be responsible for any damage that occurs during or after installation, or for any structure that has been modified by the purchaser or is used in some way other than our application recommendations.

Grounding & Protection Against Electric Shock:

The purchaser and installer must provide electrical groundings and warnings about electrical hazards in accordance with applicable codes.

Installation:

- Attach sling to top of pole.
- Attach luminaries and complete wiring.
- Place leveling nuts and washers on anchor bolts.
- Erect pole.
- Position over anchor bolts and set on leveling nut washers.
- Place anchor nuts and washers on anchor bolts and tighten once pole is plumb.

Anchor Bolt Foundation:

- The concrete foundation must be designed by a qualified engineer with knowledge of the local soil conditions.
- Anchor bolt diameter, length and psi are specifically selected to withstand load limitations listed in the catalog or quote.
- Anchorage supplied by others:
 - » Contact the factory for the correct size and strength.
 - » Maxlite will not be held responsible for the structural integrity of the system if anchor bolts are supplied by others.
- The bolt circle template provided conforms to the bolt circle of the pole base.
- When leveling nuts are used, the bottom of the lowest leveling nut shall not be more than 1" from the concrete surface.
 - » Large spaces between the pole base plate and the concrete can cause excessive stresses in the anchor bolts.

NOTE: Do not erect pole without the intended loading attached.

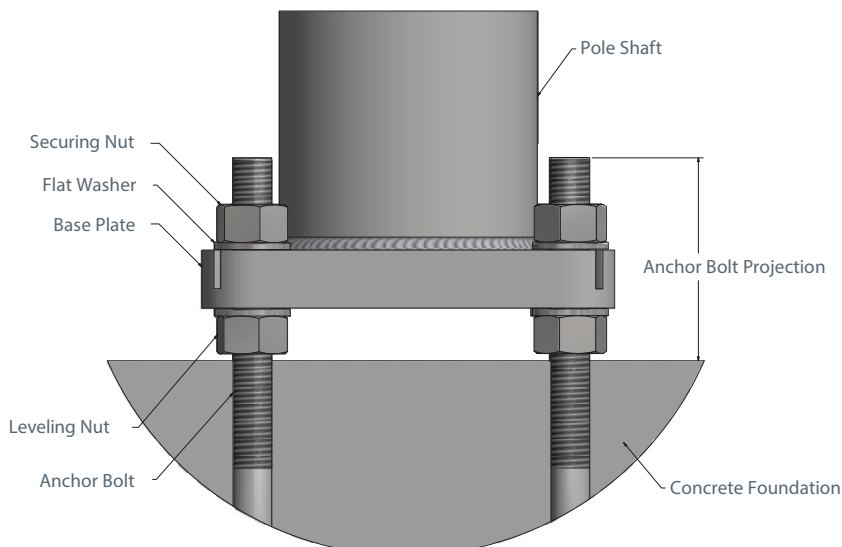



MaxLite® Square Steel Poles Installation Instructions

MaxLite Poles Small Parts Assembly

Our poles will be delivered along with the anchor bolts and template (if not pre-shipped) and also a box of hardware. The standard box of hardware includes:

- 2-piece base cover with 4 push pins
- Pole cap (drill mount only)
- Can of touch up paint (standard colors only)
- Hand hole cover with gasket and back bar
- Grounding bolt and snap plug



The box of hardware **MUST** be inspected at the time of delivery!

Certification

Welding Certification = AWS 1.1/1.2 (Poles)

Galvanizing standard = ASTM A153 (Anchor bolts)

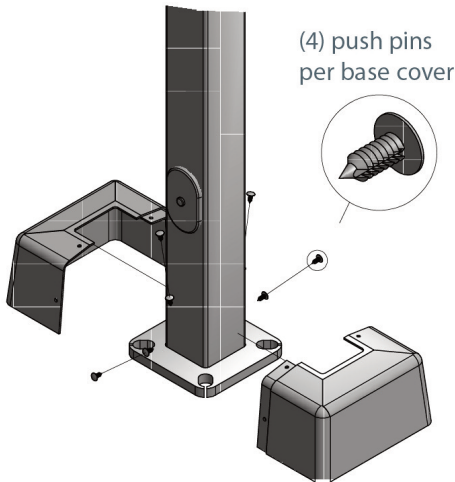

The standard base cover is a 2 piece ABS plastic that is secured with 4 push pins

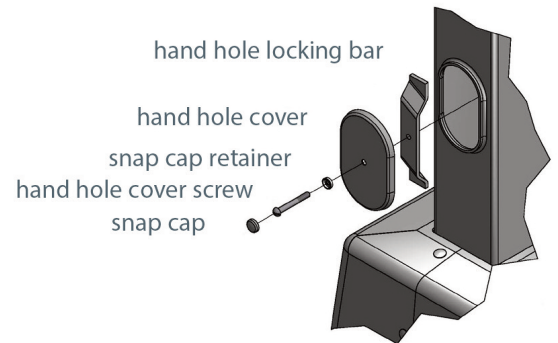
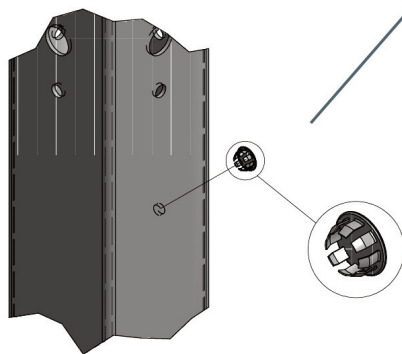

Hand hole covers are supplied with a water proofing gasket. Peel the backing and secure to the inside of the hand hole cover.

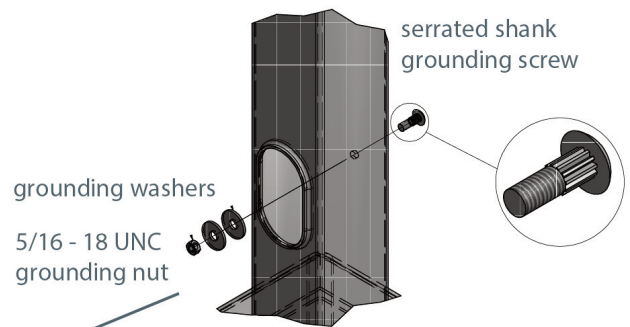
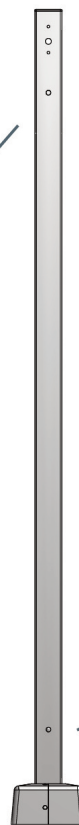

The poles must be hung in order to travel through the powder coat booth. We do this by drilling(2) holes in the pole. The hole at the top is plugged while the hole at the bottom of the pole is utilized as the Grounding Lug.

MaxLite® Square Steel Poles Installation Instructions



MaxLite Mounting Template, 4" Square, Steel

- For 11 Gauge Poles, anchor bolts are 3/4", fully galvanized
- For 07 Gauge Poles, anchor bolts are 1", partially galvanized

Note: bolt projection range above foundation 3.00 min. - 3.50 max when leveling nuts and grout are used.

SET ANCHOR BOLTS AT Ø8.50 BOLT CIRCLE.

WARNING: MaxLite will not honor any claim for incorrect anchorage placement caused from failure to use full size factory supplied templates. It is possible for downloaded files to be distorted when printing. It is the contractors responsibility to verify accurate measurements.

NOT TO SCALE. 8.00" - 9.00" BOLT CIRCLE.

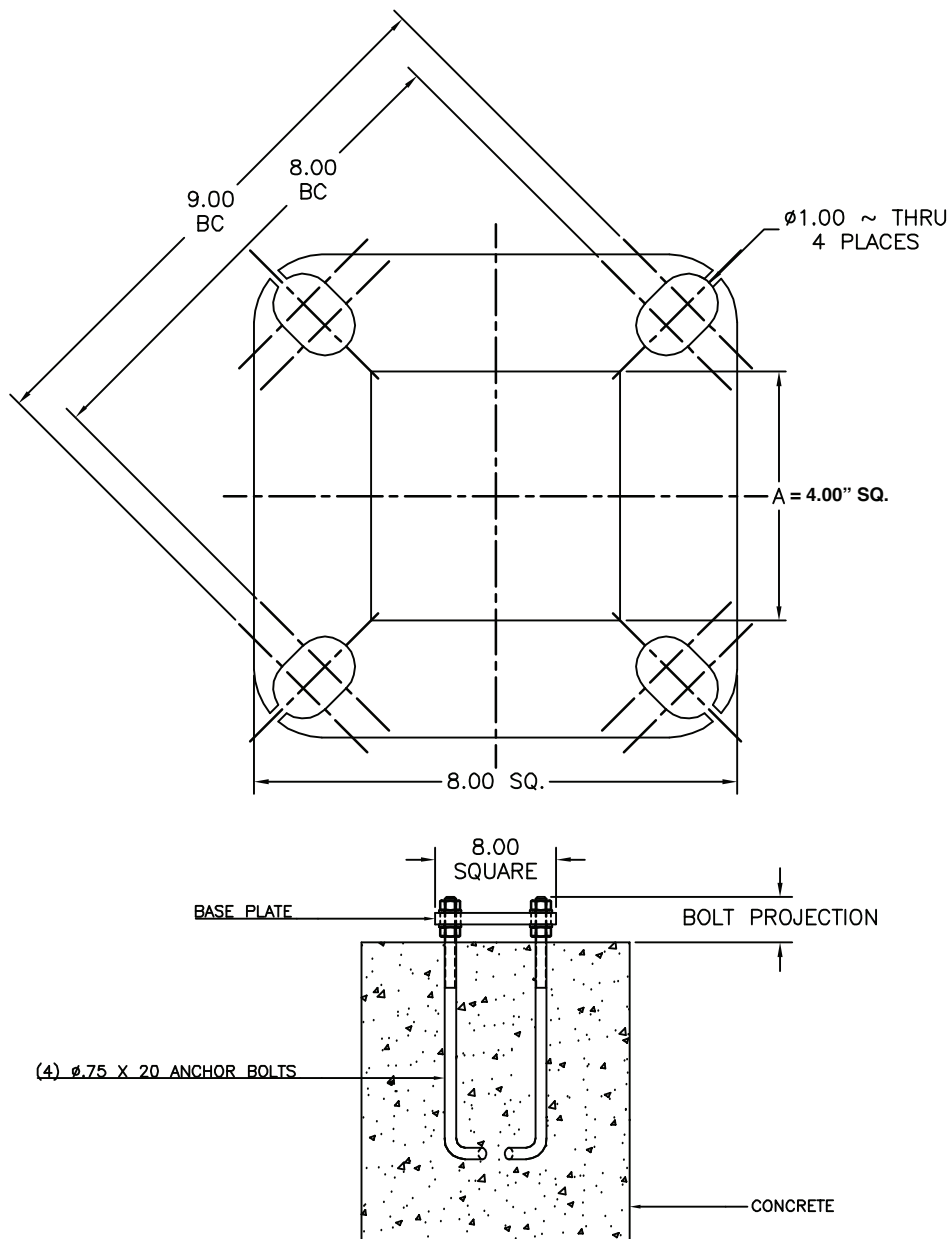

MaxLite® Square Steel Poles Installation Instructions



MaxLite Poles Mounting Template, 5" Square, Steel

- For 11 Gauge Poles, anchor bolts are 3/4", fully galvanized
- For 07 Gauge Poles, anchor bolts are 1", partially galvanized

Note: bolt projection range above foundation 3.00 min. - 3.50 max for Ø.75 and 3.50 min. - 4.00 max. For Ø1.00 when leveling nuts and grout are used.

SET ANCHOR BOLTS AT Ø11.00 BOLT CIRCLE.

WARNING: MaxLite will not honor any claim for incorrect anchorage placement caused from failure to use full size factory supplied templates. It is possible for downloaded files to be distorted when printing. It is the contractors responsibility to verify accurate measurements.

NOT TO SCALE. 10.50" - 11.50" BOLT CIRCLE.

