



MaxLite® LED Slim Flush Mount Bi-Level Motion Sensor

General Safety Information

READ AND FOLLOW ALL SAFETY INSTRUCTIONS

⚠ WARNING

WARNING: Carefully read and understand the information given in this instruction sheet before beginning the assembly and installation.

Failure to do so could lead to electric shock, fire, or other injuries which could be fatal.

- Ensure the electricity to the fixture you are working on is shut off.
- Risk of fire or electric shock. Fixture must be installed by a qualified electrician.
- To prevent wiring damage or abrasion, do not expose wiring to edges of sheet metal or other sharp objects.

NOTICE: This device complies with Part 15 of the FCC Rules. Operation is subject to the following two conditions: (1) this device may not cause harmful interference, and (2) this device must accept any interference received, including interference that may cause undesired operation. These limits are designed to provide reasonable protection against harmful interference in a residential installation. This equipment generates, uses and can radiate radio frequency energy and, if not installed and used in accordance with the instructions, may cause harmful interference to radio communications. However, there is no guarantee that interference will not occur in a particular installation. If this equipment does cause harmful interference to radio or television reception, which can be determined by turning the equipment off and on, the user is encouraged to try to correct the interference by one or more of the following measures: Reorient or relocate the receiving antenna, increase the separation between the equipment and the receiver, connect the equipment into an outlet on a circuit different from that to which the receiver is connected, and consult the dealer or an experienced radio/TV.



*Pictures are for illustration purposes only.
Your model may vary.*

Installation Instructions – Installation with J-Box

⚠ Safety Precautions

WARNING: Make sure the POWER IS TURNED OFF at the source to the in which you are installing the product.

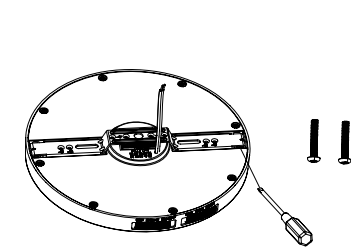

1. Take the fixture and accessory out of the box. Use a flathead screwdriver to remove the mounting bracket from the lamp.

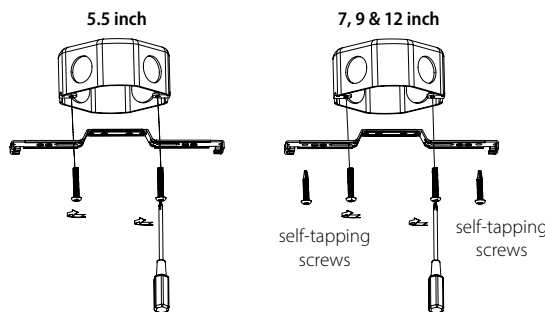

2. Fasten the mounting bracket to the junction box.
 - 5.5" – Secure the bracket with two machine screws.
 - 7", 9" & 12" – Use additional two self-tapping screws.

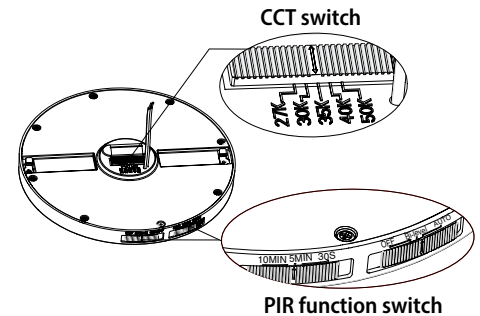

3. Select the desired color temperature and PIR function settings.

Sensor Function Tunable Switch

- **Left (OFF):** Turn off sensor function. Time set will be disabled. (Set Sensor to Off position if using an on/off wall control switch.)
- **Middle (Bi-level):** When less than 65-75Lux, the PIR sensor will operate after detected. 100% output when the PIR sensor is detected, 50% output after 30 seconds or 5 Minutes, or 10 Minutes. (30 Second or 5 Minute level will turn off after the delay time, 10 minute level will continue at half power output.)
- **Right (AUTO):** Enable sensor and time set the function. Output is at 100% when the PIR sensor is detected. 0% output after 30 Seconds or 5 Minutes.

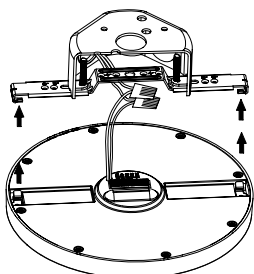

4. Wire the surface mount, white-white, black-black and green to ground wires. Once wire connections are made, secure each with a wire nut and push up into the bracket latch.

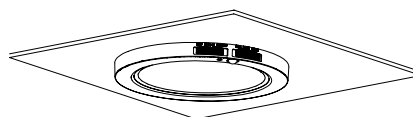

5. Finish installation.



MaxLite® LED Slim Flush Mount Bi-Level Motion Sensor

Standard Product Warranty

TERMS & CONDITIONS

Introduction

This product warranty (the "Warranty") covers each of MaxLite's LED lighting fixtures, lamps, and controls (the "Product(s)") that are purchased while the Warranty is in effect, for a specified period of time (the "Warranty Period") from the earlier of the actual installation date or 90 days after the original date of purchase from a MaxLite authorized distributor/dealer. For each Product, the Warranty Period can be found in the most current versions of the MaxLite Standard Product Warranty Coverage document ("SPWC") and applicable MaxLite Product Data Sheet ("PDS").

Warranty Coverage

If a Product fails to operate during the Warranty Period as a result of defects in materials or workmanship, MaxLite will, at its option, repair it, replace it with the same Product (or, if the same Product is not reasonably available, with a product that is comparable in MaxLite's view) at no charge, or will issue a refund. MaxLite reserves the right to utilize new, reconditioned, refurbished, repaired, or remanufactured products or parts in the warranty replacement process.

General Terms and Conditions of the Warranty

1. The Warranty is effective for purchases of Products on and after July 22, 2019. MaxLite reserves the right to modify the Warranty from time to time; any such modifications shall be effective for all purchases made on and after the effective date of such modification.
2. The Warranty is applicable only to Products originally purchased from an authorized MaxLite distributor/dealer and is otherwise void.
3. Except for Products that qualify for a labor allowance per the SPWC, MaxLite is not responsible for any of the labor costs or other expenses associated with Product removal or installation.
4. The Warranty is void if the Product is operated outside its normal operating conditions per the applicable PDS, has been installed for an application for which it is not rated, or has been subject to accident, neglect, abuse, misuse, or Acts of God, and shall only be effective if the Product has been used, installed, and maintained in accordance with MaxLite's written instructions.
5. The Warranty shall not apply to any Product which is used, installed, operated, or maintained in violation of any applicable standard, code, or instructions for use, including without limitation, those contained in the Standards for Safety of Underwriters Laboratory, Inc (UL); the National Electric Code (NEC); Standards for the American National Standards Institute (ANSI); or, in Canada, the Canadian Standards Association (CSA).
6. The Warranty does not cover any 3rd party devices or products used in conjunction with the Product unless they are purchased from or provided by MaxLite to be used specifically with the Product.
7. Repaired and/or replacement products are warranted by MaxLite for the remainder of the failed Product's original Warranty Period.
8. The Warranty shall not apply to Products, parts, advice, assistance, or service which a) MaxLite furnishes as a courtesy or for no fee, and/or b) that are purchased and/or used outside of the United States or Canada.
9. In the event that LEDs fail to operate, such shall constitute a Product defect under the Warranty only if at least 15% of the LEDs per product have stopped illuminating.
10. The Warranty does not cover any cosmetic Product defects, including without limitation, damage to the painted Product finish or other finish or coating. Nor does the Warranty cover any lumen drop-off or CCT (color temperature) variations experienced by a Product.
11. Only an Officer of MaxLite, or a designee appointed in writing by an Officer of MaxLite is authorized to change, modify or extend the terms of this Warranty.
12. The Warranty and all matters connected with the performance thereof shall be construed, interpreted, applied and governed in all respects by the laws of the State of New Jersey in the United States of America. Any action, suit or proceeding arising out of or relating to this Limited Warranty and/or to the purchase of Products covered by this Limited Warranty, shall be venued exclusively in the State or Federal courts located within the State of New Jersey (U.S.A.).
13. To make a claim under the Warranty, customer must notify MaxLite (or MaxLite's designee) in writing, during the Warranty Period, of the Product failure. All claims must be initiated using the warranty claim process found on MaxLite's website.
14. Before providing Warranty coverage, MaxLite or its designee(s): (i) may require that you provide evidence of the purchase and/or installation date (e.g. a copy of original receipt/invoice, customer order number, etc.); and (ii) shall have the right but not the obligation to inspect the relevant project job site.
15. Warranty coverage is only available if the original purchaser is not in default or arrears on any portion of its payment obligations to MaxLite for the defective Product.

LIMITATION OF LIABILITY

THIS WARRANTY IS EXCLUSIVE, AND IS THE SOLE REMEDY FOR ANY AND ALL CLAIMS, WHETHER IN CONTRACT, IN TORT OR OTHERWISE ARISING FROM THE FAILURE OF PRODUCT AND IS IN LIEU OF ALL OTHER WARRANTIES, EXPRESS OR IMPLIED, INCLUDING ALL WARRANTIES OF MERCHANTABILITY OR FITNESS FOR A PARTICULAR PURPOSE, WHICH WARRANTIES ARE HEREBY EXPRESSLY DISCLAIMED TO THE EXTENT PERMITTED BY LAW AND, IN ANY EVENT, SHALL BE LIMITED TO THE WARRANTY PERIOD SPECIFIED ABOVE. THE LIABILITY OF MAXLITE SHALL BE LIMITED TO THE TERMS OF THE EXPRESS WARRANTY SET FORTH HEREIN. IN NO EVENT WILL MAXLITE BE LIABLE FOR ANY SPECIAL, INCIDENTAL OR CONSEQUENTIAL DAMAGES INCLUDING, WITHOUT LIMITATION, DAMAGES RESULTING FROM LOSS OF USE, PROFITS, BUSINESS OR GOODWILL, LABOR COSTS, REMOVAL OR INSTALLATION COSTS, WHETHER OR NOT MAXLITE HAS BEEN ADVISED OF THE POSSIBILITY THEREOF. UNDER NO CIRCUMSTANCES SHALL MAXLITE'S ENTIRE LIABILITY FOR A DEFECTIVE PRODUCT EXCEED THE PURCHASE PRICE OF THAT PRODUCT (EXCLUDING LABOR WARRANTY COVERAGE WHERE SPECIFICALLY OFFERED BY MAXLITE). WARRANTY SERVICES PROVIDED UNDER THESE TERMS AND CONDITIONS DO NOT ENSURE THE UNINTERRUPTED OPERATION OF PRODUCTS; MAXLITE SHALL NOT BE LIABLE FOR DAMAGES CAUSED BY ANY DELAYS INVOLVING WARRANTY SERVICE.

This Warranty gives you specific legal rights and you may also have other rights that may vary from state to state. Because some states or jurisdictions do not allow the exclusion or limitation of liability for consequential or incidental damages, such limitation may not apply to you.