

PROJECT NAME: _____ CAT. #: _____
 NOTES: _____ FIXTURE SCHEDULE: _____

1-BUTTON BLUETOOTH MESH WALL DIMMER CONTROLLER -SILVAIR



WNS1DU-W-SL

Overview:

c-Max Network Partners features additional networked lighting controls proposition that seamlessly combines MaxLite’s broad c-Max controls ready luminaires with other technology partners control systems. This new wireless offering extends MaxLite’s c-Max Lighting controls solutions to now include Silvair’s Bluetooth NLC and DLC 5.0 qualified system featuring a globally interoperable lighting controls ecosystem. Multiple offering using the patented c-Max USB-C ports presents customers with controls agnostic technology choices to fit their controls and IoT needs. Built on the value proposition of c-Max controls architecture, it now brings scalable lightingcontrols in an affordable manner.

Applications:

- Offices
- Hospitals
- Schools
- Warehouses
- Industrial
- Retail

Features:

- Wirelessly communicates with other Bluetooth mesh network devices to provide light level control in the space. It can be installed in a standard 1-gang wall box.
- The unit also functions as a dimmer to override the pre-configured occupancy sensor settings.
- Easy Commissioning with Silvair App (Available in iOS and Android)
- Standard decora style opening allow for easy multi-gang installation
- LED status indicator light
- UL Listed for damp settings
- Check <https://www.maxlite.com> for c-Max fixture compatibility
- 5 Year Warranty

Specifications

PRODUCT TYPE	Wall Controller
Input Voltage	120-277VAC 50/60Hz
Power Consumption	Max. 1.5W
Neutral Required	Yes
Mounting	Standard wall box
Max Bluetooth Range	30ft (9.14m)
Operating Temperature	32°F to 130°F / 0°C to 55°C
Relative Humidity	90-95% non-condensing at 30°C
Certification	UL Listed
Cybersecurity	ioXt Certified
Environment	Indoor Use Only
Color	White

Ordering Information

MODEL NUMBER	DESCRIPTION	UPC	ORDER CODE
WNS1DU-W-SL	NETWORK SILVAIR DIMMER 120-277V WALL SWITCH WHITE	767627058424	111137

1-BUTTON BLUETOOTH MESH WALL DIMMER CONTROLLER -SILVAIR

PRODUCT DIMENSIONS

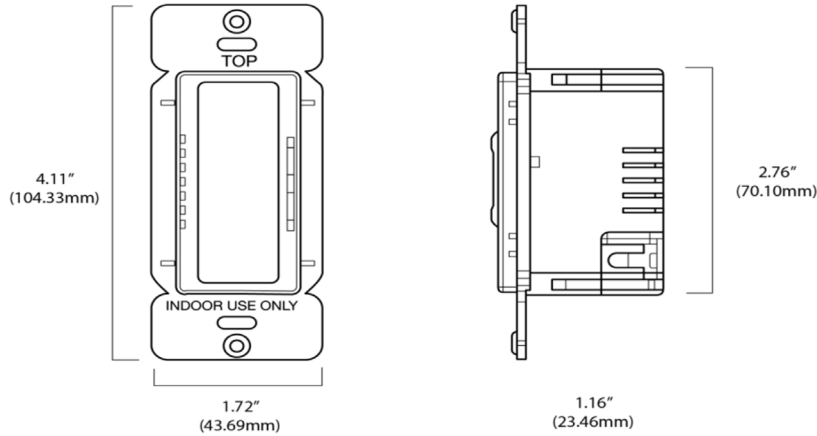

WIRING DIAGRAM

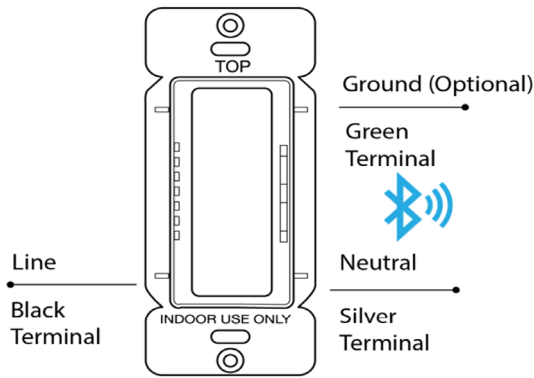

Drawings are not to scale

WALL CONFIGURATION

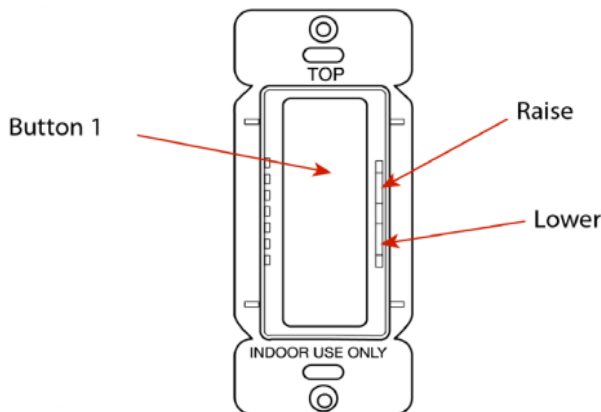

Button 1 for On/Off:

Short press - OFF

Short press - AUTO/ON

Auto = Resume automatic control; turns on the automatic settings for luminaires (defined by the settings profile).

For dimming:

Raise Toggle

Lower Toggle

Factory reset:

Press and hold Button 1 together with side toggle at top and bottom for 10 sec. The device returns to an un-provisioned state.

1-BUTTON BLUETOOTH MESH WALL DIMMER CONTROLLER -SILVAIR

Technology Partner **SILVAIR**

Silvair provides a reliable lighting control technology based on the globally interoperable Bluetooth mesh standard. Whether you are a component manufacturer, a facility manager, or an energy service company, you can easily deploy our solutions to strengthen your competitive advantage and create new revenue streams.

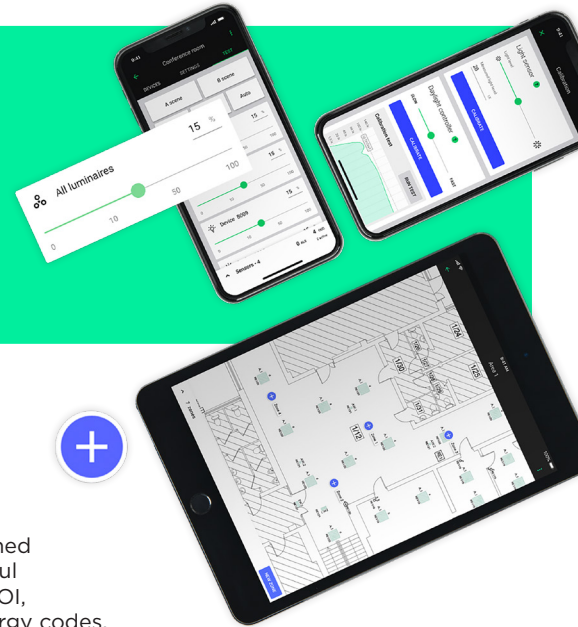

Commissioning tools for installers

Advanced strategies have never been easier

We provide intuitive apps for standard-compliant Bluetooth mesh lighting networks. Designed to support large-scale installations deployed in commercial environments, they offer powerful commissioning, fine-tuning, and everyday management features. The bottom line is faster ROI, shortened path to advanced control strategies, and facilitated compliance with building energy codes.

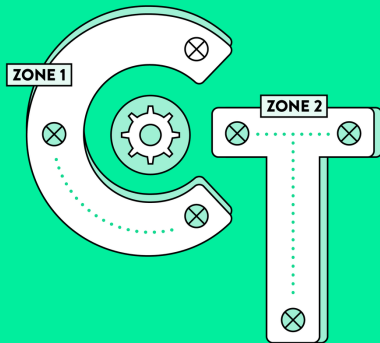

Plan every detail from the comfort of your desk

Silvair Applications

[Web App](#)

[iOS App](#)

[Android App](#)